

## BI10A Basket Bunching Head

### List Of Features

Has 16,500 lbs. of Squeezing pressure on the tips of the tines for superior holding quality of all types of wood and for all types of conditions.

Heavy Duty construction throughout using T1-100 steel and High quality welding material.

Swivel housing is completely removable and self contained (Timkin taper roller bearings, seals on both ends and a double lock nut system for added dependability).

Special bracing on the tines make them fatigue free.

Uses Heavy Duty cylinders with 1/2" wall tubing.

Uses Caterpillar type cylinder packing for extreme service.

Uses oversized pins and cylinder rods.

Uses Caterpillar type steel bushings throughout the entire head.

Inspection ports in all the locations that they **NEED** to be.

All grease nipples are in easy to see and use locations for longer life and service.

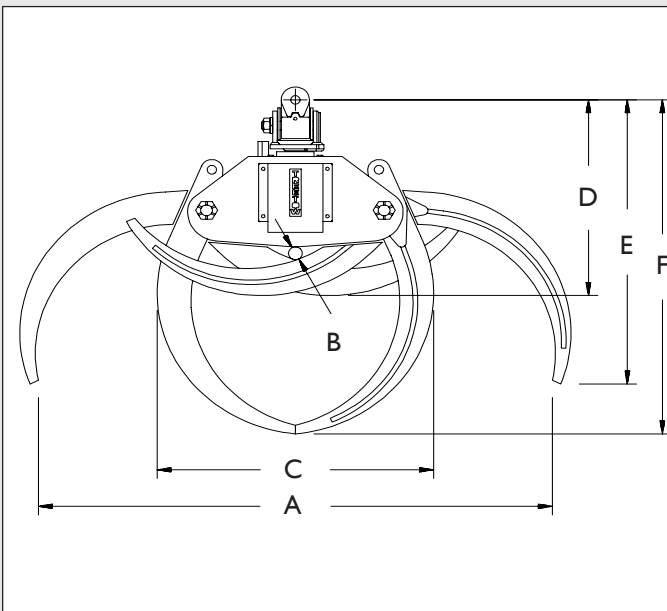

### Specifications

(A) Maximum Opening	_____	110" (2794)
(B) Minimum Opening	_____	3" (76)
(C) Maximum Width	_____	59" (1499)
(D) Height Closed	_____	45 1/2" (1155)
(E) Height Open	_____	66" (1676)
(F) Height Open Tip To Tip	_____	77 1/2" (1968)
Contained Area Tip To Tip	_____	10 1/2 sq. ft. (.84 sq. m)
Weight	_____	1,650 lbs. (750 kg)

**Brigden Manufacturing Inc.**

Bay #4, 101 Spears Rd., Quesnel, B.C., Canada, V2J-4Z3 Sales Office 1 800 665 2530 - (250) 992-3710 Fax (250) 992-3841

TREETOW is a registered trade mark of Brigden Manufacturing Inc. Printed in Canada