

TREETOW

Model# S65C5 Steep Slope Grapple
Caterpillar D5H TSK Modified Track

- **Main Boom frame** is a full **See Through** structure which allows the operator to easily see the load at all times. Optional **Fairlead roller** attachment to allow for line skidding in restricted terrain and rescuing other machines.
- **New Style Jib** allows the grapple to be carried close to the rear of the machine like never before.
- **Grapple reach** travel is 64" which allows the positioning of the load to give more traction and stability.
- **Variable Grapple Height** can be adjusted on a vertical plane with the boom in the full ahead position. This enables the center of gravity of the machine to be as far ahead and as low as possible.
- **Ground Clearance** is not hampered by this attachment.
- **Attachment Weight** is approximately 4600 lbs / 2090 kg
- **Ground Pressure** with modified 8 roller track frame and 26" Pad Width is **6.40 lbs. Per Sq. In.**
- **Replacement Parts**
 - Cat steel bushings.
 - Standard inch size ball bushings.
 - Timken taper roller bearings.
 - Charlynn hydraulic motor.
 - Hardware is all SAE Grade 8.
- **Hydraulic Cylinders**
 - Heavy Duty 1/2" wall tubing.
 - Induction Hardened Chrome Plated cylinder rod Shafting.
 - High Quality Cat Seals.
- **Winch Option**-Carco #50B.
- **Grapple Head Options**
 - G101B Tong grapple head (standard)
 - B110A Basket bunching head (optional)
 - B120C Basket bunching head (optional)

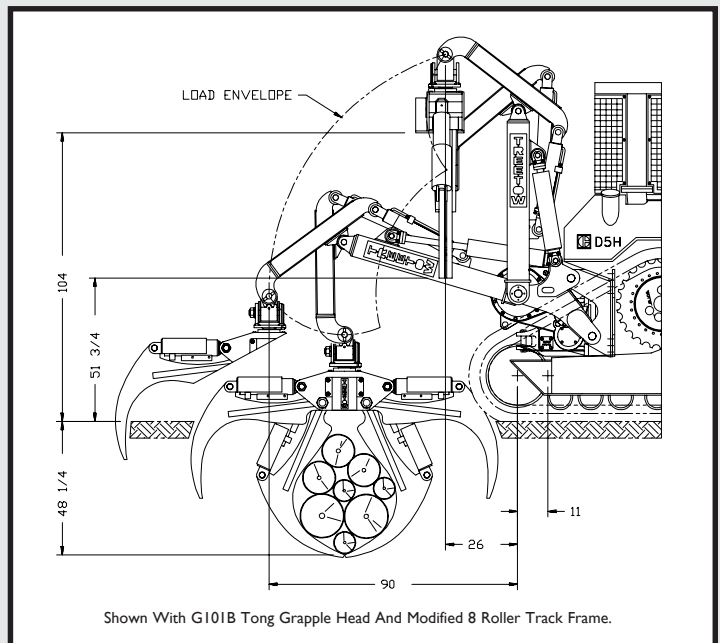

Brigden Manufacturing Inc.

Bay #4, 101 Spears Rd., Quesnel, B.C., Canada, V2J-4Z3 Sales Office 1 800 665 2530 - (250) 992-3710 Fax (250) 992-3841

TREETOW is a registered trade mark of Brigden Manufacturing Inc. Printed in Canada